



SAILING INSTRUCTIONS

Incorporating the 2023 Victorian Para Sailing Championships

Organising Authority: Royal Brighton Yacht Club

With support from Victorian partner clubs:
Black Rock Yacht Club (BRYC), Mordialloc Sailing Club (MSC)
and Sorrento Sailing Couta Boat Club (SSCBC)

Version 1.2

Incorporating Notice to Competitors 12

1 CHANGES TO SAILING INSTRUCTIONS

- 1.1 Changes to the format or schedule of races will be posted on the Official Notice Board by 20:00 hrs on the day before it will take effect and any change to the sailing instructions will be posted before 09:00 hrs on the day it will take effect.
- 1.2 Any reassignment of classes to course areas will be posted before 09:00 hrs on the day it will take effect, or if flag AP is displayed ashore, 30 minutes before flag AP for that class is removed.
- 1.3 When any SI Addendum is changed, an updated version of it will be posted on the Official Notice Board.

2 COMMUNICATIONS WITH COMPETITORS

The [Official Notice Board](http://www.sailmelbourne.com.au) (ONB) will be an online notice board located at www.sailmelbourne.com.au. All protests, scoring enquiries, equipment and crew change requests will be submitted via the ONB and resulting notices posted online.

3 SIGNALS MADE ASHORE

- 3.1 Signals made ashore will be displayed at the flag masts at Royal Brighton Yacht Club boat park.
- 3.2 When flag AP is displayed ashore, '1 minute' is replaced with 'not less than 30 minutes' in the race signal AP. This changes race signal AP.
- 3.3 **[DP]** Flag AP over H displayed ashore means 'Boats shall not leave the harbour. Wait for further instructions.' This adds to Race Signals.
- 3.4 Visual signals made ashore may be posted on the Official Notice Board

4 [DP] CODE OF CONDUCT

- 4.1 Competitors and support persons shall comply with reasonable requests from race officials.

5 SCHEDULE OF RACES

- 5.1 The total number of races scheduled is as per the Event Schedule NOR Attachment A. One extra race per day may be sailed, provided that no fleet becomes more than one race ahead of schedule.
- 5.2 The daily race schedule and the scheduled time of the warning signal for the first race is shown at Addendum B. The scheduled time of the first warning signal for subsequent days will be promulgated as a Notice to Competitors on the ONB.
- 5.3 The warning signal for each succeeding race will be made as soon as practicable after the completion of the previous race.
- 5.4 To alert boats that a race or sequence of races will begin soon, the orange starting line flag will be displayed with one sound for at least five minutes before a warning signal is displayed. This changes RRS Race Signals.

6 FORMAT OF RACING

- 6.1 The format is a Single Series. If the race committee deems it necessary to split a class into fleets, then separate instructions will be issued.

7 RACING AREAS

See SI Addendum A.

8 CLASS FLAGS

8.1 See SI Addendum C

9 THE COURSES

- 9.1 The diagrams in SI Addendum C show the courses, the course designations, the order in which marks are to be passed, and the side on which each mark is to be left.
- 9.2 No later than the warning signal, the race committee signal vessel will display the course designation and may display the approximate compass bearing of the first leg.
- 9.3 If one of the gates marks is not laid, then the laid mark shall be left to port.

10 MARKS

10.1 See SI Addendum C.

11 THE START

- 11.1 Class fleets may be started in any order, and some class fleets may be started together.
- 11.2 The starting line will be between a staff displaying an orange flag on the race committee vessel at the starboard end and either:
- the course side of the port-end inflatable starting mark, or
 - a staff displaying an orange flag on the race committee vessel at the port end.
- 11.3 **[DP]** Boats whose warning signal has not been made shall avoid the starting area during the starting sequence for other classes. The starting area is defined as a rectangle 50 meters from the starting line and marks in all directions.
- 11.4 A boat that does not start within 4 minutes after her starting signal, or for Charlie course 3 minutes, will be scored Did Not Start without a hearing. This changes RRS 35, Appendix A5.1 and Appendix A5.2.
- 11.5 **[DP] iQFOiL Only.** The race committee may signal that boards shall sail on a specific tack during the 10 seconds before and 10 seconds after the starting signal is made, by displaying a green flag for starboard tack or a red flag for port tack, before or with the warning signal.
- 11.6 iQFOiL/KiteFoil races will be started by using the following signals. Times shall be taken from the visual signals - the absence of a sound signal shall be disregarded. This changes RRS B3 26.

Minutes before starting signal	Visual signal	Sound signal	Means
3	<i>Class flag</i>	<i>One</i>	<i>Warning signal</i>
2	<i>P, U, or black flag</i>	<i>One</i>	<i>Preparatory signal</i>
1	<i>Preparatory flag removed</i>	<i>One long</i>	<i>One minute</i>
0	<i>Class flag removed</i>	<i>One</i>	<i>Starting signal</i>

12 CHANGE OF THE NEXT LEG OF THE COURSE

To change the next leg of the course, the race committee will lay a new mark (or move the gate or move the finishing line) and remove the original mark as soon as practicable. When in a subsequent change a new mark is replaced, it will be replaced by an original mark.

13 THE FINISH

- 13.1 The finishing line will be between a staff displaying a Blue flag on the race committee vessel and either:
- the course side of the nearby inflatable finishing mark, or
 - a staff displaying a Blue flag on the nearby race committee vessel.
- 13.2 **[DP]** Boats finishing shall keep clear of boats about to start where reasonably practicable.
- 13.3 For iQFOiL Women and Youth only, boats which are still deemed to be racing by the race committee but are outside the Finish Window may be scored an allocated place based on their position when the Time Limit expires. Such boats may be directed to return to the start area or other location without crossing the finish line. Neither the allocation of a finish place nor the failure to allocate a finish place will be grounds for redress. This changes RRS 35, RRS 62.1, RRS Appendix A5.1, A5.2 and A10.

14 TIME LIMITS AND TARGET TIMES

- 14.1 See SI Addendum C.
- 14.2 If no boat has passed Mark 1 within the Mark 1 Time Limit the race may be abandoned. Failure to meet the target times will not be grounds for protest. This changes RRS 62.1(a).
- 14.3 Boats failing to finish within the time stated in the Finish Window after the first boat starts, sails the course and finishes will be scored Did Not Finish, except as provided for in SI 13.3. This changes RRS 35, RRS Appendix A5.1 and A5.2.

15 HEARING REQUESTS

- 15.1 The Organising Authority has appointed an International Jury for this event.
- 15.2 Protests shall be submitted via the ONB.
- 15.3 For each class, the protest time limit is 60 minutes after the last boat has finished the last race of the day or the race committee signals no more racing today, whichever is the later.
- 15.4 Notices will be posted no later than 30 minutes after the protest time limit to inform competitors of hearings in which they are parties. Hearings will be held at RBYC Committee Room beginning at the time posted. Hearings may be scheduled to begin up to 30 minutes before the end of the protest time limit.
- 15.5 Notices of protests by the race committee, technical committee or jury will be posted to inform boats under RRS 61.1(b).
- 15.6 A list of boats that have been penalized under Appendix P for breaking RRS 42 will be posted.
- 15.7 On the last scheduled day of racing, a request for reopening a hearing shall be delivered;
- within the protest time limit if the requesting party was informed of the decision on the previous day;
 - no later than 30 minutes after the requesting party was informed of the decision on that day. This changes RRS 62.2.

16 SCORING

- 16.1 Three races are required to be completed to constitute a series.
- 16.2 When fewer than five races have been completed, a boat's regatta score will be the total of her race scores.
- 16.3 When five to nine races have been completed, a boat's regatta score will be the total of her race scores excluding her worst score.
- 16.4 When ten or more races have been completed a boat's regatta score will be the total of her race scores excluding her two worst scores.
- 16.5 KiteFoil only. There will be one discard after every five (5) races that are completed and scored.
- 16.6 Scoring for the Victorian Para Sailing Championships will be drawn from the overall fleet results for the 2.4mR class.
- 16.7 iQFOil – Slalom Racing
 - a) All competitors may be assigned together for each slalom race.
 - b) Two slalom races are required on the one day to complete a slalom round.
 - c) Points scored in those races will determine the competitors overall place in that round. The round will be abandoned and may be re-sailed on another day if fewer than two races are completed on the one day.
 - d) More than one round may be completed on any day.
 - e) The scoring of one slalom round is equal to that of one course race and is treated as that when determining the competitor's overall regatta score.

17 [NP] SAFETY REGULATIONS

- 17.1 **[SP]** Competitors shall wear personal flotation devices in accordance with NOR 1.1 at all times while afloat, except briefly while changing or adjusting clothing or personal equipment.
- 17.2 Numbered bibs will be provided by the organising authority for the WingFoil and Kite competition. Bibs shall be collected from the Race Management Representative at the Beach, worn at all times while racing and returned to the Race Management Representative no later than 30 minutes after the last finisher in, or abandonment of, the last race of the regatta.
- 17.3 Boats not leaving the harbour for a scheduled race shall promptly use the electronic sign on/off system by selecting "Not Sailing Today".
- 17.4 **[SP]** Before leaving to race on each scheduled racing day, a crew shall sign-on electronically using the online sign on/off system.
- 17.5 **[SP]** After returning to shore on each scheduled racing day, a crew shall sign-off electronically using the online sign on/off system within the protest time limit.
- 17.6 Instructions for use of electronic sign on/off system:
 - a) Competitors shall provide a contact mobile phone number on the entry system.
 - b) Competitors will receive a text message prior to the first race containing a link to the sign on system.
 - c) Prior to leaving the shore, competitors shall click on the link, select the "Sign on/off" link in the menu and select either "Sign on" or "Not Sailing Today".
 - d) On returning to shore after racing, competitors shall click on the "Sign Off" link.
 - e) If a competitor is having issues with the sign on/off contact the regatta office or Kite beach marshal who will manually sign you on/off.

- 17.7 **[DP]** A boat that retires from racing shall notify the race committee before leaving the racing area, or if that is not possible, shall notify the race office as soon as possible after returning ashore and shall complete a retirement declaration in the online notice board before the expiry of the protest time limit.
- 17.8 **[DP]** Boats shall not sail into other course areas whilst the other course areas are racing. Boats not racing shall remain clear of boats that are racing and official boats.
- 17.9 Race Management VHF Channels – See SI Addendum C.
- 17.10 **[DP]** Race officials and race committee vessels may retrieve boat crews and return them to their boats for safety reasons. The sail number of a boat which receives outside help will be notified to the Race Committee with details of the incident and a hearing may be held (if required) to determine any penalty. This changes RRS 41.

18 **[DP]** REPLACEMENT OF CREW OR EQUIPMENT

- 18.1 Substitution of competitors will not be allowed without prior written approval of the race committee via the Online Notice Board and shall comply with any restrictions in the Notice of Race.
- 18.2 Substitution of skippers will not be allowed after close of Registration for the applicable class.
- 18.3 Substitution of damaged or lost equipment will not be allowed unless approved by the race committee. Requests for substitution shall be made to the race committee at the first reasonable opportunity via the Online Notice Board. When equipment is substituted during a series of races on the same day, the request shall be made before the protest time limit expires on the day via the online form.

19 **[DP]** **[NP]** EQUIPMENT AND MEASUREMENT CHECKS

Equipment may be inspected at any time for compliance with the class rules and sailing instructions. When instructed by a member of the technical committee, a boat shall proceed immediately to a designated area for inspection.

20 OFFICIAL VESSELS

- 20.1 Official vessels will be marked as follows:

Equipment Inspection	Flag with letter M or Measurer
Judges	White Flag with letter J
Media	White Flag with letter M
Race Committee	Course designation – A, B, C or D
Rescue	White flag with RBYC crest
PRO	Flag with letters PRO

- 20.2 Actions by official vessels, drones or helicopters shall not be grounds for requesting redress by a boat. This changes RRS 60.1(b).

21 **[DP]** PARA CLASSES HAUL OUT RESTRICTIONS

Para Classes boats shall not be hauled out during the event except with and according to the terms of prior written permission of the race committee.

COURSE AREAS

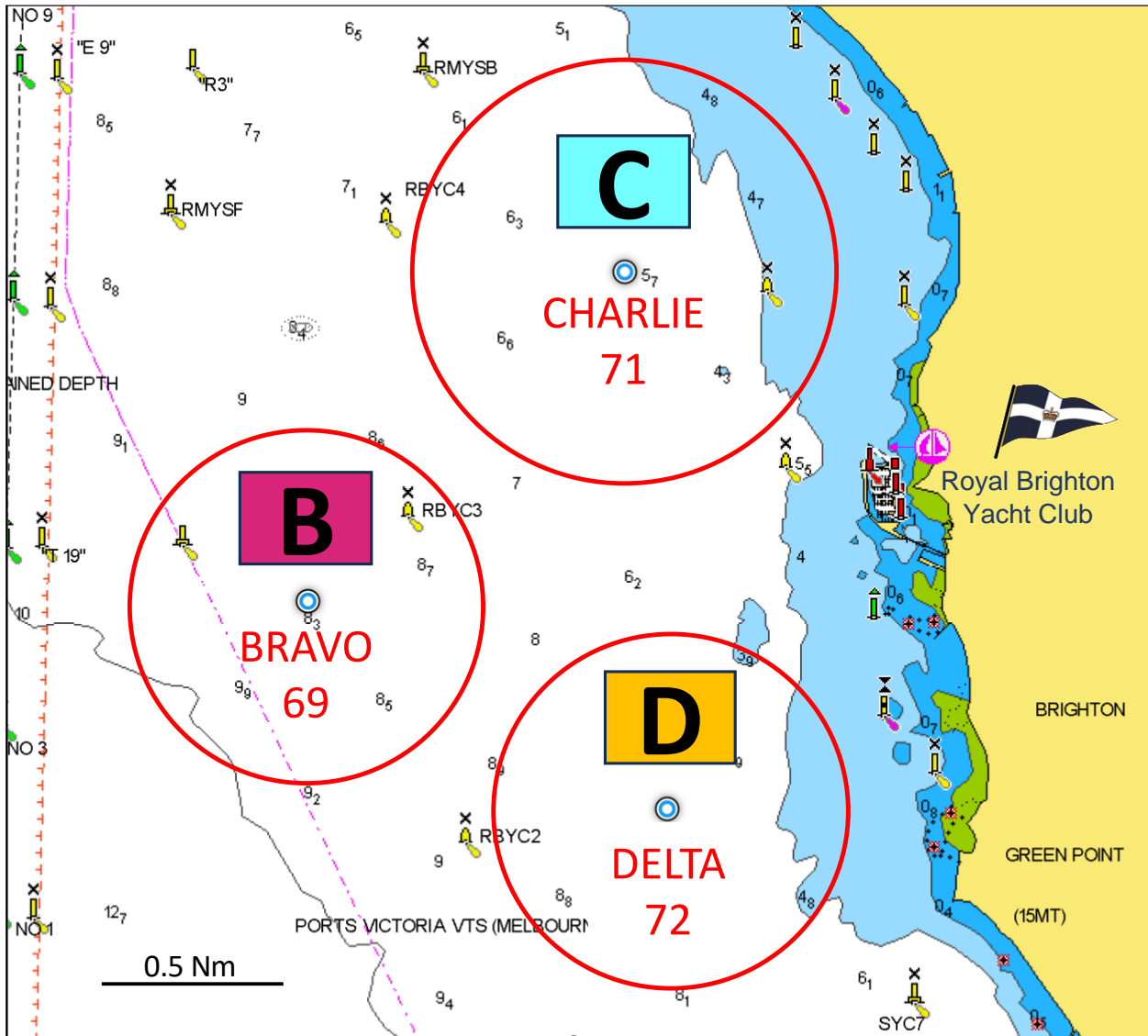

Course Centres:

ALPHA	Sorrento
BRAVO	37° 53.7'S, 144° 56.8'E
CHARLIE	37° 53.7'S, 144° 57.9'E
DELTA	37° 55.4'S, 144° 58.1'E

SCHEDULE OF RACES

CLASS			Thu 30 Nov	Fri 1 Dec	Sat 2 Dec	Sun 3 Dec
ILCA 4 ILCA 6 ILCA 7	BRAVO RBVC	Races Warning	Up to 3 races 1300	Up to 3 races 1300	Up to 3 races	Up to 3 races
470	CHARLIE MSC	Races Warning	Up to 3 races 1300	Up to 3 races 1300	Up to 3 races	Up to 3 races
2.4mR		Races Warning		Up to 3 races 1300	Up to 3 races	Up to 3 races
Tasar		Races Warning			Up to 3 races 1300	Up to 3 races
Opti - Open		Races Warning			Up to 3 races 1300	Up to 3 races
Opti - Inter		Races Warning			Up to 3 races 1300	Up to 3 races
iQFOiL	DELTA BRYC	Races Warning	Up to 4 races 1330	Up to 4 races 1330	Up to 4 races	Up to 4 races
KiteFoil		Races Warning	Up to 5 races 1330	Up to 5 races 1300	Up to 5 races	Up to 5 races

Times of the first warning signal on subsequent days will be promulgated by a Notice to Competitors on the ONB by 20:00 hrs on the day before it will take effect.

BRAVO Course – VHF 69

Classes

Class	Class Insignia	B'ground Colour	Finish Time Limit	Mark 1 Time Limit	Finish Window	Target Time
ALL CLASSES	B					
ILCA 4	ILCA	Yellow	75	20	15	50
ILCA 6	ILCA	Green	75	20	15	50
ILCA 7	ILCA	White	75	20	15	50

Description of Marks

Start pin	Orange buoy or race vessel
Finish LR pin	B&W check buoy
Finish T pin	B&W check buoy
Mark 1i	Pink buoy
Mark 1o	Yellow buoy
Mark 2o	Yellow buoy
Marks 3p/3s	Orange buoy
Marks 4p/4s	Orange buoy
Mark 5	Pink buoy

Courses

Class		Mark Rounding Order
ILCA 4	LR2	Start – 1i – 4p/4s – 1i – 4p – Finish LR
ILCA 6	LR2	Start – 1o – 4p/4s – 1o – 4p – Finish LR
	I2	Start – 1o – 4p/4s – 1o – 2o – 3p – 5 – Finish T
ILCA 7	02	Start – 1o – 2o – 3p/3s – 2o – 3p – 5 – Finish T
	LR2	Start – 1o – 4p/4s – 1o – 4p – Finish LR
	I2	Start – 1o – 4p/4s – 1o – 2o – 3p – 5 – Finish T
	02	Start – 1o – 2o – 3p/3s – 2o – 3p – 5 – Finish T

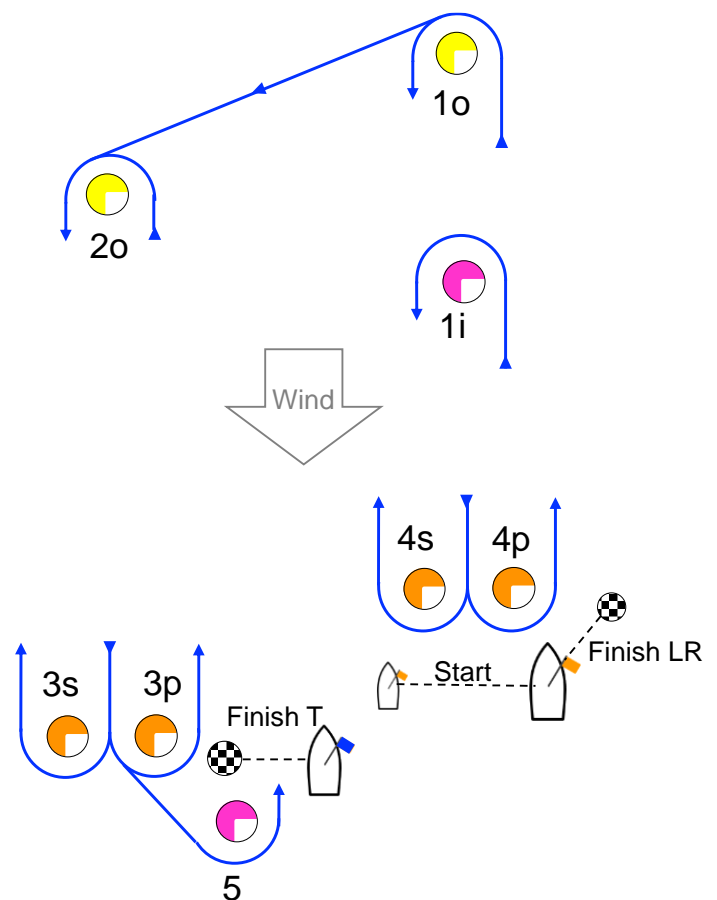

CHARLIE Course – VHF 71

Classes

Class	Class Insignia	B'ground Colour	Finish Time Limit	Mark 1 Time Limit	Finish Window	Target Time
ALL CLASSES	C					
470	470	Blue	60	25	15	40
Tasar	Tasar	White	60	15	15	45
2.4mR	2.4mR	White	60	25	15	40
Optimist - Open	Opti Blue	White	55	20	15	35
Optimist - Intermediate	Opti White	Blue	50	20	15	30

Description of Marks

		Change Mark
Start pin	Race vessel	
Finish pins	Black & White check buoy	
Mark 1i	Orange buoy	Orange buoy with black band
Mark 1o	Yellow buoy	Yellow buoy with black band
Mark 2	Yellow buoy	
Mark 3p/3s	Yellow buoys	
Mark 4p/4s	Yellow buoys	

Courses

470 / Tasar

Course	Mark Rounding Order
LR2	Start – 1o – 4s/4p – 1i – 4p – Finish LR
LR3	Start – 1o – 4s/4p – 1o – 4s/4p – 1o – 4p – Finish LR

Class	Mark Rounding Order
2.4mR	Start – 1i – 4s/4p – 1i – 4s/4p – 1i – 4p - Finish LR
Optimist - Open	Start – 1i – 2 – 3s/3p – 2 – 3p – Finish T
Optimist - Intermediate	Start – 1i – 2 – 3p - Finish T

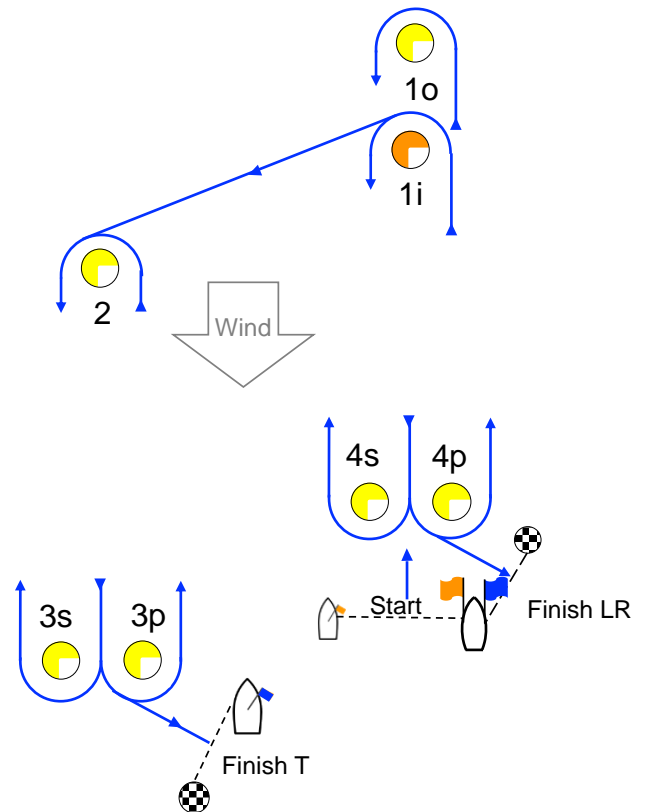

DELTA Course – VHF 72

Classes

Class	Class Insignia	B'ground Colour	Finish Time Limit	Mark 1 Time Limit	Finish Window	Target Time
ALL CLASSES	D					
iQFOIL Men	White	Red				
iQFOIL Women	Red	White				
iQFOIL Youth	White	Blue				
	Course Racing		23		6	16
	Sprint Slalom		7		4	4-5
IKA KiteFoil	White	Blue	20	10	10	10

Description of Marks

iQFOILs / IKA KiteFoil – Windward/Leeward

Start pin	Orange buoy
Finish pin	Black & White buoy
Mark 1	Pink buoy
Mark 1i	Orange buoy
Marks 4P & 4S	Pink buoy

Signal	Mark Rounding Order
LR2*	Start – 1 – 4s/4p – 1 – 4p – Finish LR
LR3*	Start – 1 – 4s/4p – 1 – 4s/4p – 1 – 4p – Finish LR

*** iQFOIL Women and Youth to round Mark 1i, NOT 1**

iQFOIL - Slalom

Start pin	Orange buoy
Finish Pin	Black & White buoy
Marks A, B & C	Yellow buoy

Signal	Mark Rounding Order
S4	Start – A – B – C – Finish SS

IKA KiteFoil – XS

Start pin	Orange buoy
Finish Pin	Black & White buoy
Marks 1, 4 & 5	Pink buoy
Mark P	Orange buoy

Signal	Mark Rounding Order
XS2	Start – Pp – 1p – Pp – 4s – Pp – 1p – Pp – 4s – 5p - Finish
XS3	Start – Pp – 1p – Pp – 4s – Pp – 1p – Pp – 4s – Pp – 1p – Pp – 4s – 5p – Finish

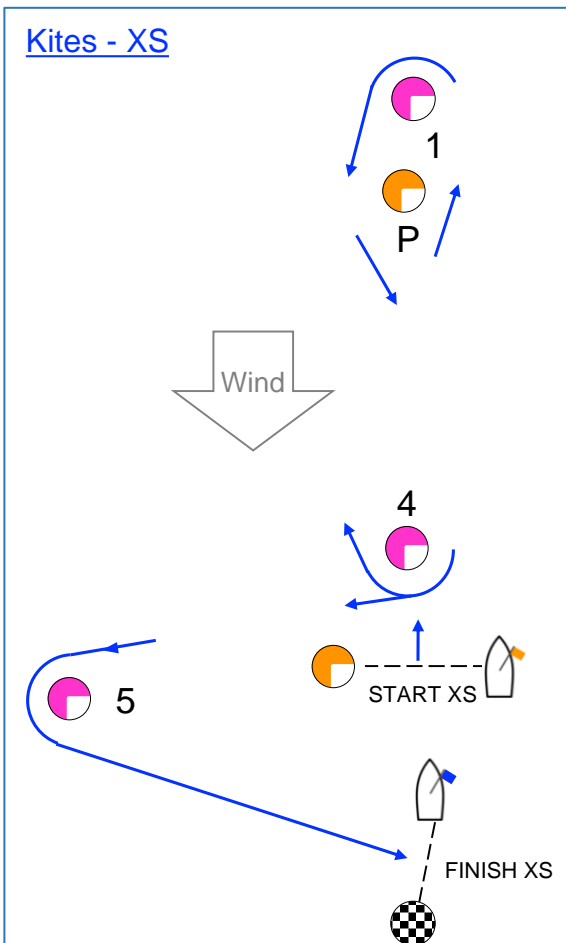
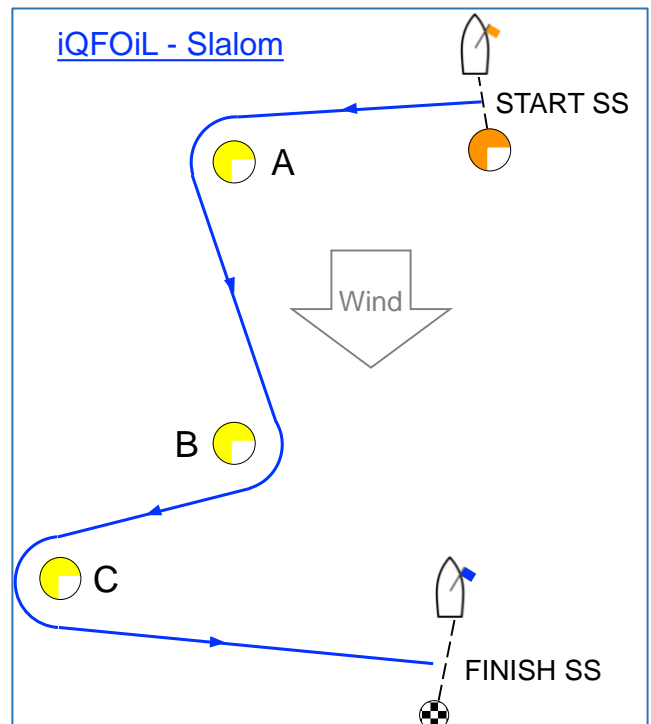
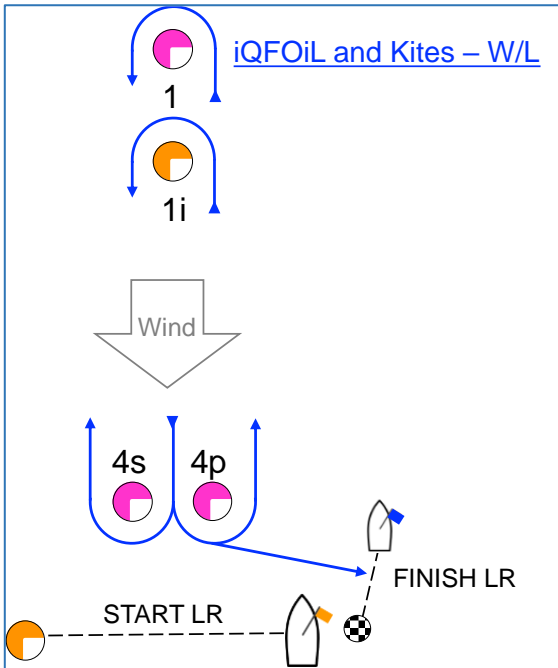

Standard Penalties

The Race Committee may apply a standard penalty without a hearing, or a discretionary penalty may be applied by the International Jury with a hearing.

The Race Committee may protest a boat if it considers a standard penalty is inappropriate.

SAFETY	
Not wearing a personal flotation device in accordance with NOR 1.1 (SI 17.1)	One point scoring penalty added to all races in which the infringement occurs
Not signing on (SI 17.4)	One point scoring penalty added to the first race of the day
Not signing off (SI 17.5)	One point scoring penalty added to the last race of the day